

UC353A

(Deep UV LED)

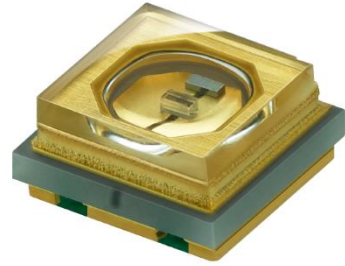

Use of Samsung's deep ultraviolet light technology

Features & Benefits

- Deep ultraviolet LED
- Wavelength between 270nm to 280nm
- SMT solderable
- Lead Free product



Applications

- Surface disinfection
- Air disinfection
- Water disinfection

Table of Contents

1.	Characteristics	-----	3
2.	Product Code Information	-----	5
3.	Typical Characteristics Graphs	-----	6
4.	Outline Drawing & Dimension	-----	8
5.	Reliability Test Items & Condition	-----	9
6.	Soldering Conditions	-----	10
7.	Tape & Reel	-----	11
8.	Label Structure	-----	13
9.	Packing Structure	-----	14
10.	Precautions in Handling & Use	-----	16

1. Characteristics

a) Absolute Maximum Rating

Item	Symbol	Rating	Unit	Condition
Ambient / Operating Temperature	T_a	-40 ~ +60	°C	-
Storage Temperature	T_{stg}	-40 ~ +100	°C	-
LED Junction Temperature	T_{j-s}	90	°C	-
Forward Current	I_F	40	mA	-
Assembly Process Temperature	-	260 <10	°C s	-
ESD (HBM)	-	±2	kV	-

b) Electro-optical Characteristics (@30mA)

Item	Symbol	Value	Unit
Peak Wavelength	λ_p	275	nm
Radiant Flux	Φ_e	3.7	mW
Forward Voltage	V_f	5.8	V
Thermal Resistance (junction to solder point)	R_{th}	60	K/W
Spectrum Half Width	$\Delta\lambda$	12	nm
View Angle	$2\theta_{1/2}$	120	deg

Note:

Samsung maintains measurement tolerance of: Radiant flux = ±10%, forward voltage = ±3%, Peak Wavelength = ±3nm

c) Bin Structure (@30mA)

Item	BIN Code	Min	Typ	Max
Forward Voltage (V)	54	5.4		5.6
	56	5.6		5.8
	58	5.8		6.0
	60	6.0		6.2
Peak Wavelength (nm)	70	270		280
Radiant Flux (mW)	30	3.0		3.5
	35	3.5		4.0
	40	4.0		4.5
	45	4.5		5.0

All of the above bins are in the range 0.12 – 0.17mW (@1.5mA)

2. Product Code Information

1	2	3	4	5	6	7	8	9	10	11	12	13	14	15	16	17	18
S	P	M	U	V	1	3	5	J	3	D	0	V	0	W	0	P	0

Digit	PKG Information	Code	Specification			
1 2 3	Samsung Package Middle Power	SPM				
4 5	Color	UV	Ultra Violet			
6	Product Version	1	1st version			
7 8	Product Size	35	3.5*3.5mm			
9	Product Thickness	J	1.75mm			
10	Sorting Current (mA)	3	30mA			
11	Peak Wavelength Range	D	270~280nm			
12	Sorting Temperature	0	Room Temperature			
13 14	Forward Voltage (V)	V0	V0 : 5.4 ~ 6.2V	Bin Code	54 : 5.4 ~ 5.6V 56 : 5.6 ~ 5.8V 58 : 5.8 ~ 6.0V 60 : 6.0 ~ 6.2V	
15 16	Peak Wavelength (nm)	W0	W0 : 270 ~ 280nm	Bin Code	70 : 270 ~ 280nm	
17 18	Radiant Power (mW)	P0	P0 : 3.0 ~ 5.0 mW	Bin Code	30 : 3.0 ~ 3.5 mW 35 : 3.5 ~ 4.0 mW 40 : 4.0 ~ 4.5 mW 45 : 4.5 ~ 5.0 mW	

3. Typical Characteristics Graphs

a) Spectrum Distribution ($I_f = 30\text{mA}$, $T_s = 25^\circ\text{C}$)

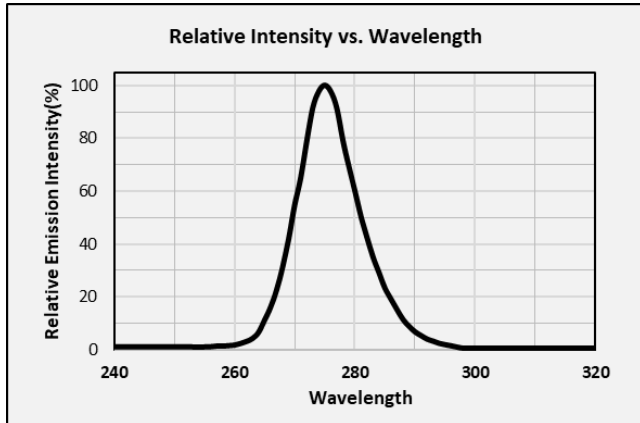

b) Forward Current Characteristics ($T_s = 25^\circ\text{C}$)

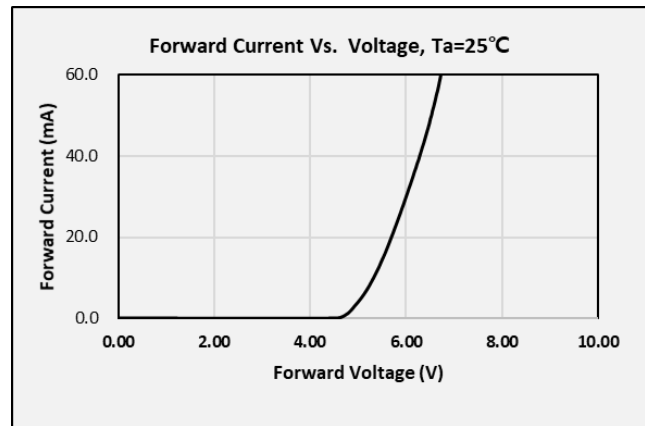
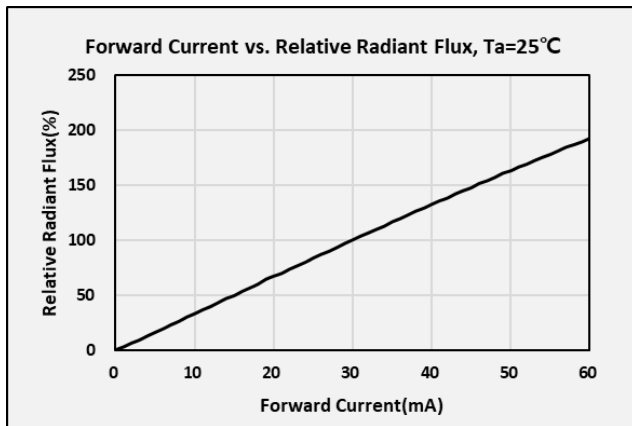

c) Beam Angle Characteristics ($I_f = 30\text{mA}$, $T_s=25^\circ\text{C}$)

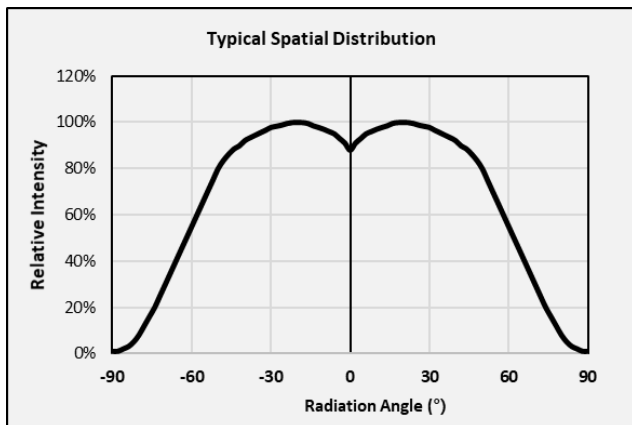

d) Temperature Characteristics ($I_F = 30 \text{ mA}$)

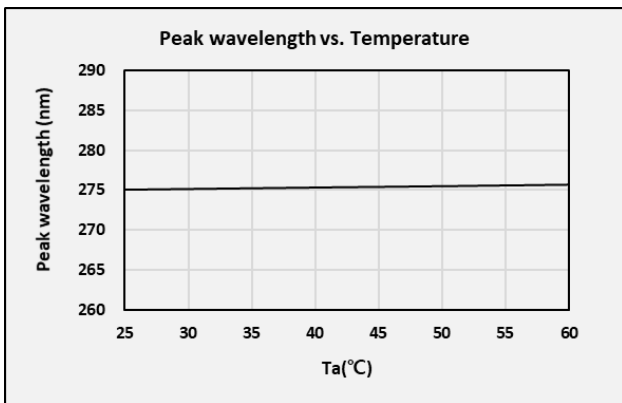
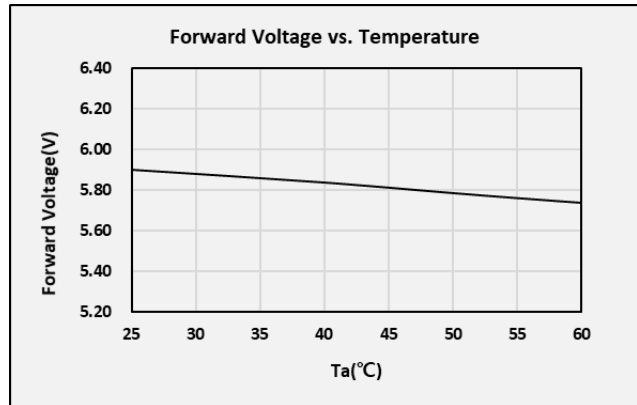
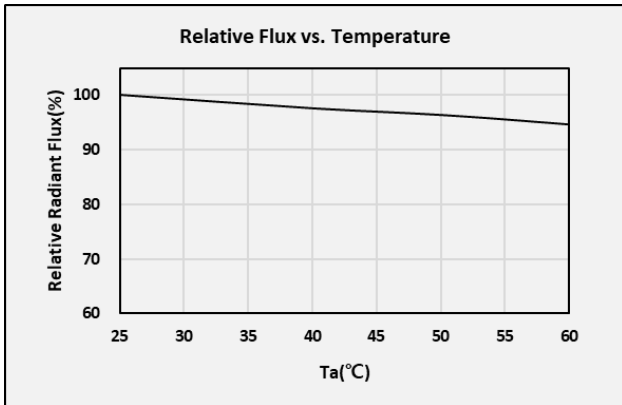

4. Outline Drawing & Dimension

a) Mechanical Dimension

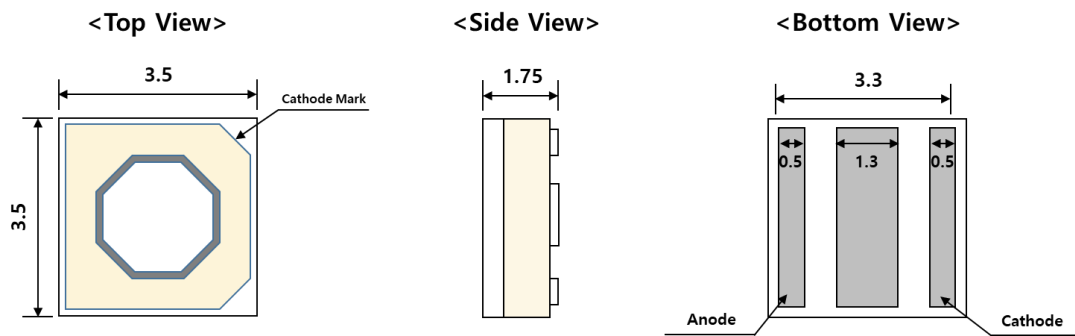

- Measurement unit: mm
- Tolerance: ± 0.15 mm

b) Recommended foot-print for SMT

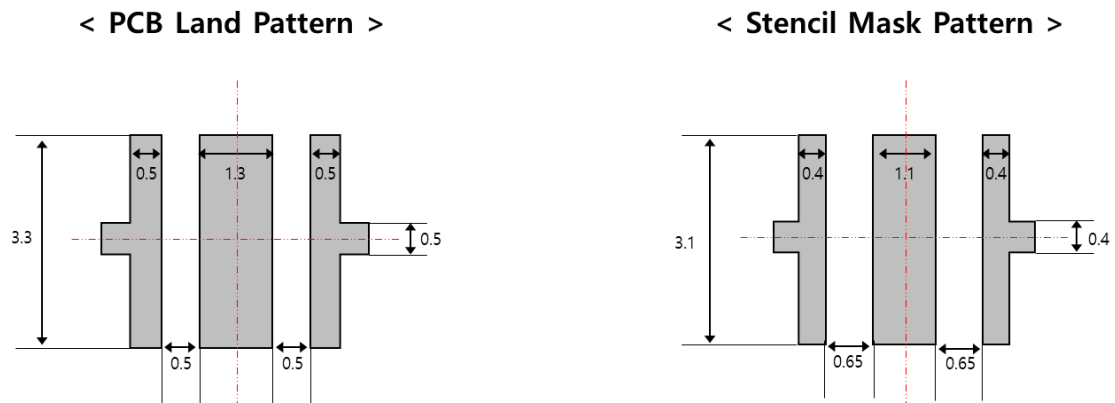

- Measurement unit: mm
- Tolerance: ± 0.15 mm

Notes:

- 1) This LED has built-in ESD protection device(s) connected in parallel to LED chip(s).
- 2) The thermal pad is electrically isolated from the anode and cathode contact pads.
- 3) Ts point and measurement method:
 - ① Measure the nearest point to thermal pad as shown above. If necessary, remove PSR of PCB to reach Ts point.
 - ② All pads must be soldered to the PCB to dissipate heat properly, otherwise the LED can be damaged.

Precautions:

- 1) Pressure on the LEDs will influence to the reliability of the LEDs. Precautions should be taken to avoid strong pressure on the LEDs. Do not put stress on the LEDs during heating.
- 2) Re-soldering should not be done after the LEDs have been soldered. If re-soldering is unavoidable, LED's characteristics should be carefully checked before and after such repair.
- 3) Do not stack assembled PCBs together. Since materials of LEDs is soft, abrasion between two PCB assembled with LED might cause catastrophic failure of the LEDs.

5. Reliability Test Items & Conditions

a) Test Items

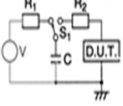
Test Item	Test Condition	Test Hour / Cycle	Sample Size
Room Temperature Life Test	25°C, Maximum rated drive current	1000 h	20
High Temperature Humidity Life Test	40°C, 90% RH, Maximum rated drive current	500 h	20
High Temperature Humidity On/Off Test	40°C, 90% RH , On/Off 5sec, Maximum rated drive current	500 h	20
Temperature Cycling	-30 °C / 30 min ↔ 120 °C / 30 min temperature change within 5 min	300 cycles	100
High Temperature Humidity Storage	40°C, 90% RH	500 h	20
High Temperature Storage	100 °C	500 h	2
Low Temperature Storage	-40 °C	500 h	20
ESD (HBM)	 <p> R₁: 10 MΩ R₂: 1.5 kΩ C: 100 pF V: ±5 kV </p>	5 times	30

b) Criteria for Judging the Damage

Item	Symbol	Test Condition (T _s = 25 °C)	Max or Min Allowable shift value
Forward Voltage	V _F	I _F = 30 mA	Max : Init. Value * 1.2
Radiant Flux	Φ _e	I _F = 30 mA	Min : Init. Value * 0.7

6. Soldering Conditions

a) Reflow Conditions (Pb free)

Reflow frequency: 2 times max.

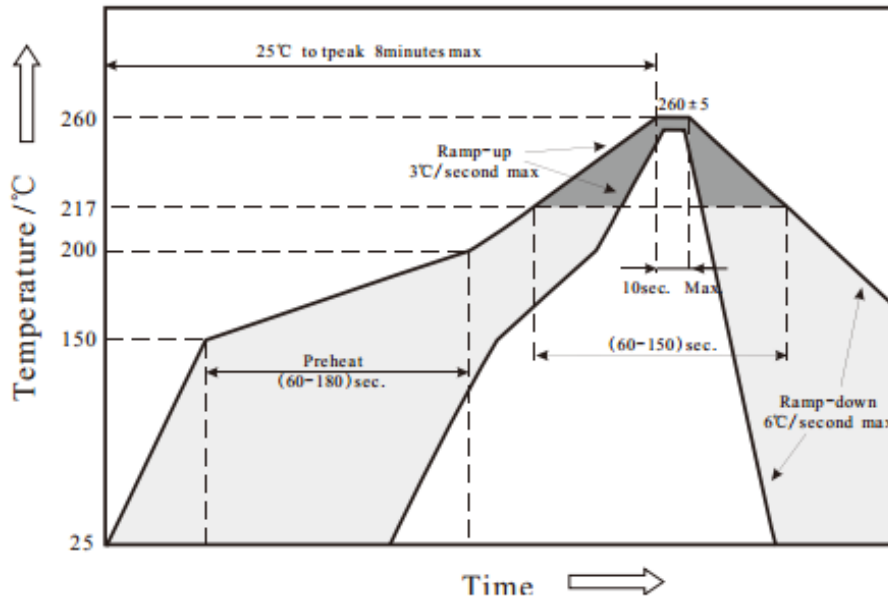

b) Manual Soldering Conditions

No more than 5 seconds @ max. 300 °C, under soldering iron.

7. Tape & Reel

a) Taping Dimension

(unit: mm)

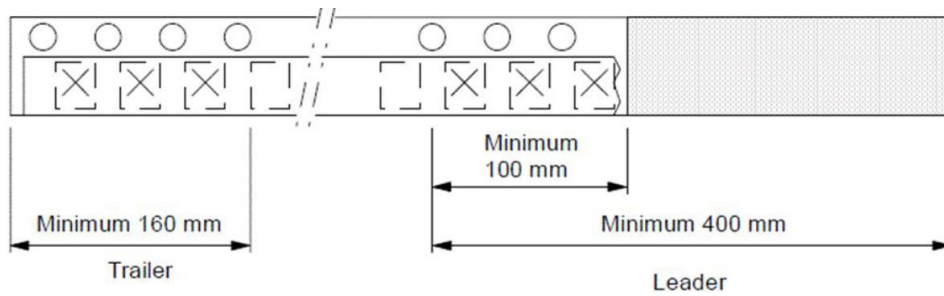
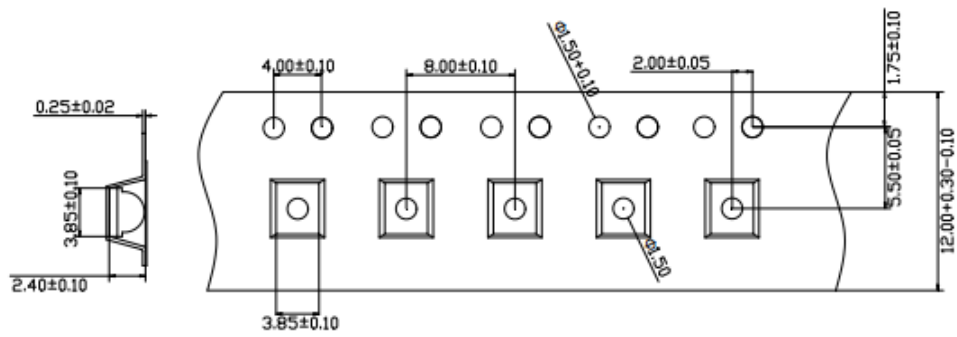

Taping Direction

b) Reel Dimension

(unit: mm)

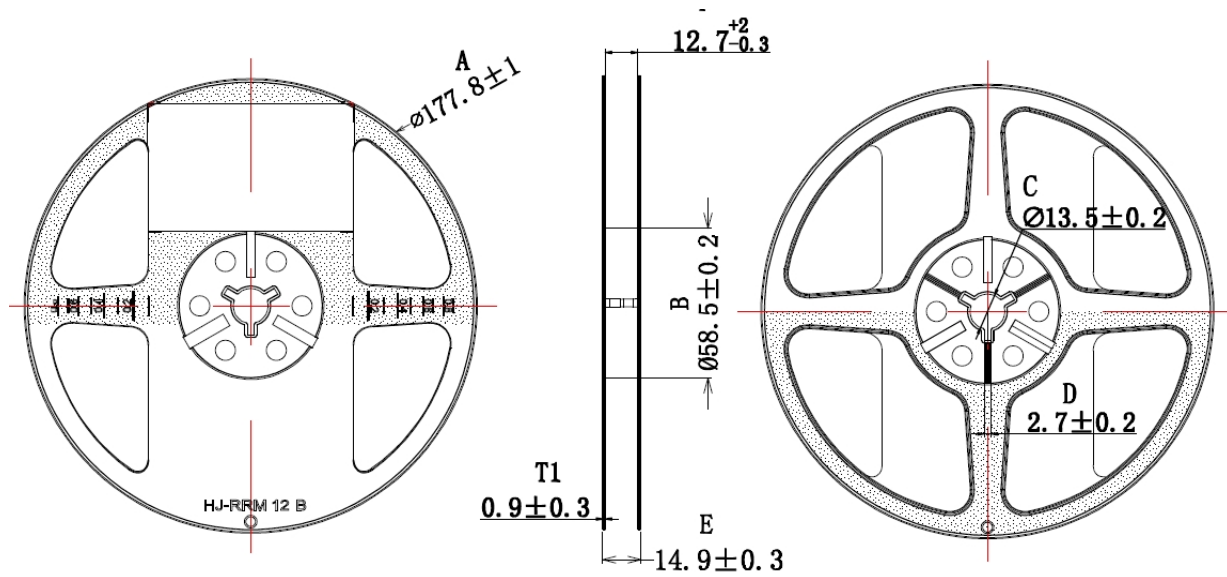

Notes:

- 1) Quantity: The quantity/reel is 1000 pcs
- 2) Cumulative tolerance: Cumulative tolerance / 10 pitches is ± 0.2 mm
- 3) Adhesion strength of cover tape: Adhesion strength is 0.1-0.7 N when the cover tape is turned off from the carrier tape at 10° angle to the carrier tape
- 4) Packaging: P/N, Manufacturing data code no. and quantity are indicated on the aluminum packing bag

8. Label Structure

a) Label Structure

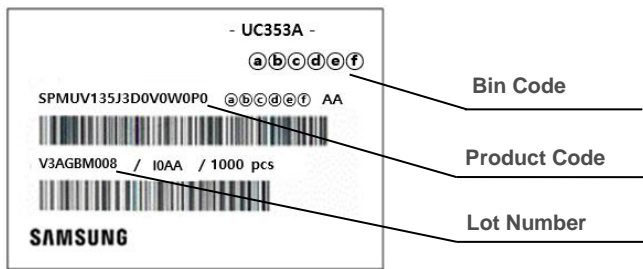

Note: Denoted bin code and product code above is only an example (see description on page 5)

Bin Code:

- ⒶⒷ: Forward Voltage bin (refer to page 5)
- ⒸⒹ: Wavelength bin (refer to page 5)
- ⒺⒻ: Radiant Flux bin (refer to page 5)

b) Lot Number

The lot number is composed of the following characters:

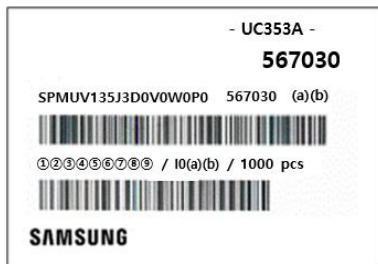

①②③④⑤⑥⑦⑧⑨ / 10(a)(b) / 1000 pcs

- ①, ② : Production site (V3 : Foshan , China)
- ③ : Product state (A: Normal, B: Bulk, C: First Production, R: Reproduction, S: Sample)
- ④ : Year (E: 2020, F: 2021, G: 2022, ...)
- ⑤ : Month (1~9, A, B, C)
- ⑥ : Day (1~9, A, B~V)
- ⑦⑧⑨ : Product serial number (001 ~ 999)
- (a)(b) : Reel number (AA, AB, AC, ...)

9. Packing Structure

a) Packing Process

Reel

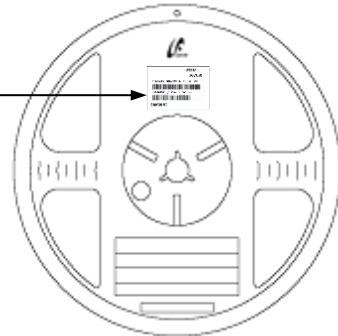

Aluminum Vinyl Packing Bag



Outer Box

Material: Paper SW(B)

Type	Size (mm)			Note
	(a)	(b)	(c)	
7 inch (L)	245 ± 5	220 ± 5	182 ± 5	Up to 8 reels
7 inch (S)	245 ± 5	220 ± 5	86 ± 5	Up to 4 reels

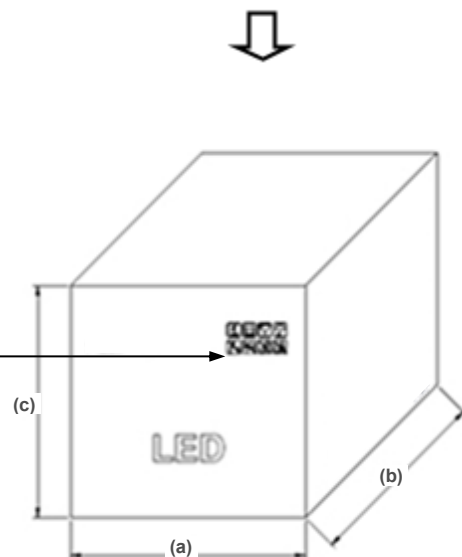

b) Aluminum Vinyl Packing Bag



CAUTION

This bag contains
MOISTURE SENSITIVE DEVICES

LEVEL
2a

- UC353A -
567030

SPMUV135J3D0V0W0P0 567030 AA



V3AGBM008 / 10AA / 1000 pcs



SAMSUNG

1. Shelf life in sealed bag: 12 months at <40°C and <90% relative humidity (RH)

2. Peak package body temperature: 240 °C

3. After this bag is opened, devices that will be subjected to reflow solder or other high temperature processes must be:

- a. Mounted within 672 hours at factory conditions of equal to or less than 30°C /60% RH, or
- b. Stored at <10% RH

4. Devices require bake, before mounting, if:

- a. Humidity Indicator Card is >65% when read at 23±5°C, or
- b. 2a is not met.

5. If baking is required, devices must be baked for 1 hours at 60±5°C

Note: If device containers cannot be subjected to high temperature or shorter bake times are desired, reference IPC/JEDEC J-STD-033 for bake procedure.

Bag seal due date: _____

(if blank, see code label)

Note: Level and body temperature by IPC/JEDEC J-STD-020



ATTENTION

OBSEVE PRECAUTIONS
FOR HANDLING
ELECTROSTATIC
SENSITIVE
DEVICES



주의 사항

이 알루미늄 지퍼 백은 습기 및 정전기로부터 제품을 보호하기 위하여 제작되었습니다. 개봉 후에는 즉시 솔더 작업을 실시하는 것을 권장합니다.

습기 및 정전기로부터 제품을 보호 하기 위해서 개봉 후 사용하지 않는 자재는 본 팩에 넣어 보관 하시기 바랍니다. 사용하지 않는 자재를 본 팩에 넣을 때는 반드시 동봉된 드라이 팩과 함께 넣고 지퍼부분을 완전하게 밀봉하여 주시기 바랍니다.

Important

This Al Zipper bag is designed to protect the enclosed products from moisture and ESD. Once opened, the products should be soldered onto the printed circuit board immediately. When not in use, please do not leave the products unprotected by the Al Zipper Bag. To repack unused products., please ensure the zip-lock is completely sealed with the dry pack left inside.

c) Silica Gel & Humidity Indicator Card inside Aluminum Vinyl Bag

HUMIDITY INDICATOR
Cobalt-Free

Bake Units if Blue

Bake Units if Blue

Change Desiccant if Blue

Discard if Circles Overrun
Avoid Metal Contact

 15%
 10%
 5%

10. Precautions in



Handling & Use

- 1) For over-current protection, users are recommended to apply resistors connected in series with the LEDs to mitigate sudden change of the forward current caused by shift of forward voltage.
- 2) This device should not be used in any type of fluid such as water, oil, organic solvent, etc. When cleaning is required, IPA is recommended as the cleaning agent. Some solvent-based cleaning agent may damage the silicone resins used in the device.
- 3) When the device is in operation, the forward current should be carefully determined considering the maximum ambient temperature and corresponding junction temperature.
- 4) LEDs must be stored in a clean environment. If the LEDs are to be stored for three months or more after being shipped from Samsung, they should be packed with a nitrogen-filled container (shelf life of sealed bags is 12 months at temperature 0~40 °C, 0~90 % RH).
- 5) After storage bag is opened, device subjected to soldering, solder reflow, or other high temperature processes must be:
 - a. Mounted within 672 hours (28 days) at an assembly line with a condition of no more than 30 °C / 60 % RH, or
 - b. Stored at <10 % RH
- 6) Repack unused devices with anti-moisture packing, fold to close any opening and then store in a dry place.
- 7) Devices require baking before mounting, if humidity card reading is >60 % at 23 ± 5 °C.
- 8) Devices must be baked for 1 hour at 60 ± 5 °C, if baking is required.
- 9) The LEDs are sensitive to the static electricity and surge current. It is recommended to use a wrist band or anti-electrostatic glove when handling the LEDs. If voltage exceeding the absolute maximum rating is applied to LEDs, it may cause damage or even destruction to LED devices. Damaged LEDs may show some unusual characteristics such as increase in leakage current, lowered turn-on voltage, or abnormal lighting of LEDs at low current.
- 10) VOCs (Volatile Organic Compounds) can be generated from adhesives, flux, hardener or organic additives used in luminaires (fixtures). Transparent LED silicone encapsulant is permeable to those chemicals and they may lead to a discoloration of encapsulant when they exposed to heat or light. This phenomenon can cause a significant loss of light emitted (output) from the luminaires. In order to prevent these problems, we recommend users to know the physical properties of materials used in luminaires and they must be carefully selected.

Legal and additional information.

[About Samsung Electronics Co., Ltd.](#)

Samsung Electronics Co. Ltd inspires the world and shapes the future with transformative ideas and technologies. The company is redefining the worlds of TVs, smartphones, wearable devices, tablets, digital appliances, network systems, and semiconductor and LED solutions. For the latest news, please visit the Samsung Newsroom at <http://news.samsung.com>.

Copyright © 2020 Samsung Electronics Co., Ltd. All rights reserved.
Samsung is a registered trademark of Samsung Electronics Co., Ltd.
Specifications and designs are subject to change without notice. Non-metric weights and measurements are approximate. All data were deemed correct at time of creation. Samsung is not liable for errors or omissions. All brand, product, service names and logos are trademarks and/or registered trademarks of their respective owners and are hereby recognized and acknowledged.

Samsung Electronics Co., Ltd.
1, Samsung-ro
Giheung-gu
Yongin-si, Gyeonggi-do, 17113
KOREA

www.samsungled.com

SAMSUNG